

Driver: \_\_\_\_\_ Date: \_\_\_\_\_ Event/Track: \_\_\_\_\_  
 Qualify: \_\_\_\_\_ Final: \_\_\_\_\_ Best Lap: \_\_\_\_\_

#### TRACK TYPE

Grip Level  High  Medium  Low   
 Type  Tight  Open  Mixed   
 Condition  Flat  Bumpy  Mixed   
 Surface  Clay  Long Astro  Carpet   
 Grass  Short Astro  Mixed   
 Weather \_\_\_\_\_

#### TYRES

	FRONT	REAR
Tyres	_____	_____
Wheels	_____	_____
Inserts	_____	_____

Notes:

Notes:

#### FRONT SUSPENSION

KEY: P = Plastic, A = Alloy, B = Brass, CF = Carbon Fibre, S2 = Schumacher Composite, M = Medium, S = Stiff, Sh = Short, H = High, L = Low, F = Front, R = Rear, Y = Yes, N = No

Ride Height \_\_\_\_\_ mm  
 Wheelbase  0  +1.5  +3.0  +4.5  
 Toe \_\_\_\_\_ deg In  Out   
 Camber at Ride Height \_\_\_\_\_ deg  
 Anti Roll Bar  0.9  1.0  1.1  1.2  
 Front Wing  Y  N   
 Bump Steer Washers \_\_\_\_\_ mm  
 Pivot Block Height  H  M  L  
 Steering Arm  Kit  A  B  C

Notes:

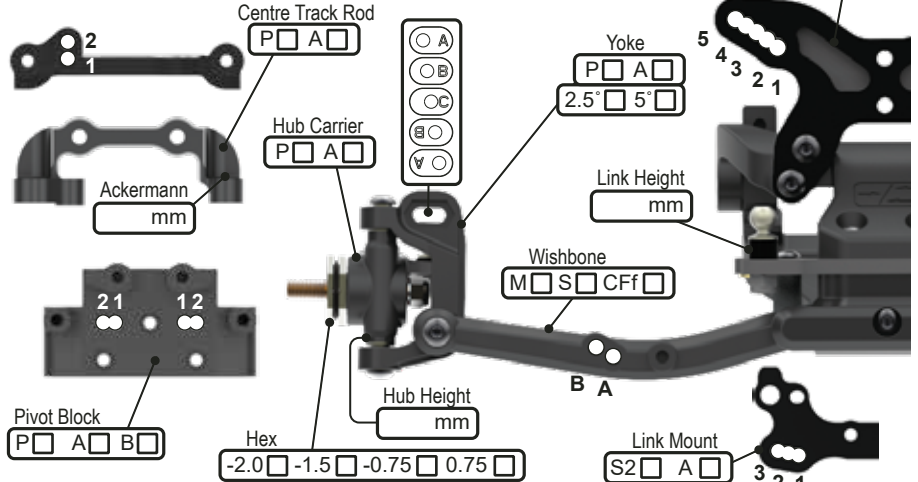

#### REAR SUSPENSION

KEY: P = Plastic, A = Alloy, B = Brass, CF = Carbon Fibre, S2 = Schumacher Composite, M = Medium, S = Stiff, Sh = Short, H = High, L = Low, F = Front, R = Rear, Y = Yes, N = No

Ride Height \_\_\_\_\_ mm  
 Wheelbase  0  +2  +4  +6  
 Anti-Squat  1°  2°  3°  4°  
 Toe  4°  3.5°  3°  2.5°  2°  1.5°  1.0°  0.5°  
 Camber at Ride Height \_\_\_\_\_ deg  
 Anti Roll Bar  1.0  1.1  1.2  1.3  1.4  
 Wing Gurney Height \_\_\_\_\_ mm  
 Rearward Shock Position  Y  N   
 Driveshaft Type  CVD  U/J   
 Gearbox Type  Laydown  Layback

Notes:

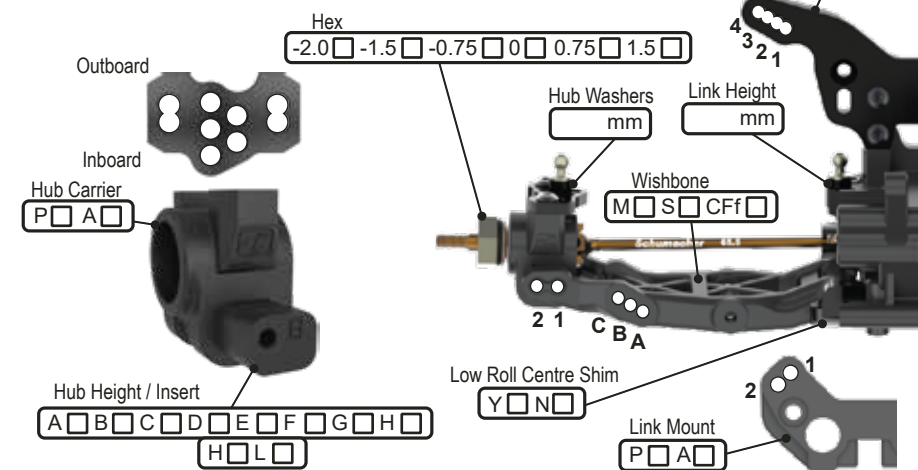

#### TRANSMISSION

B = Ball, 2g = 2 Gear, 4g = 4 Gear

Diff Height  H  M  L   
 Diff Oil \_\_\_\_\_ cSt  
 Diff Type  B  2g  4g   
 Motor \_\_\_\_\_  
 Rotor Dia. \_\_\_\_\_ mm  
 Timing \_\_\_\_\_ deg  
 Pinion \_\_\_\_\_ t  
 Spur \_\_\_\_\_ t  
 Motor Plate  A  CF   
 Lock Out  Y  N   
 Slipper Plates  2  3

#### CHASSIS

Chassis  A  C/F   
 Chassis Insert  0mm  +5mm   
 LiPo Position  
 1  2  3  4  5  6  7  8  
 X Brace  Y  N   
 Running Weight \_\_\_\_\_ g  
 Radio Tray  1  2  3   
 Notes:

#### EQUIPMENT

E.S.C. \_\_\_\_\_  
 Servo \_\_\_\_\_  
 RX \_\_\_\_\_  
 LiPo \_\_\_\_\_  
 Bodyshell \_\_\_\_\_

#### WEIGHTS

Chassis  F  R   
 Rear Strap  F  R   
 Radio Tray  Y  N   
 Under LiPo  Y  N

#### SHOCKS

KEY: i = Internal, e = External, V = Vented, S = Sealed, A = Aeration

	FRONT	REAR
Cap	<input type="checkbox"/> V <input type="checkbox"/> S <input type="checkbox"/> A <input type="checkbox"/>	<input type="checkbox"/> V <input type="checkbox"/> S <input type="checkbox"/> A <input type="checkbox"/>
Body	_____	_____
Oil	_____ cSt	_____ cSt
Piston	_____	_____
Spring	_____ lb/in	_____ lb/in
Limiters (i)	_____ mm	_____ mm
Stroke	_____ mm	_____ mm
Limiters (e)	_____ mm	_____ mm

Notes:

